

Galvanic Isolated DC - Power

XPU 700-600-DC

Suitable for Electrical Drives Test Benches



The XPU 700 power supply series is a modular, high performance DC-DC converter with galvanic isolation and is specially designed for electrical drive test benches. With a power rating of 50 kW to 250 kW and a fully bi-directional design it offers a variable output voltage of up to 700 V with a current rating of up to ± 600 A. The flexible control allows easy adaptations to different test bench environments including battery behavior emulation.

EXEPTIONAL TEST BENCH TOPOLOGY

In conventional setups two standard 3-phase converters are used to power the load machine as well as the test drive. Both converters require an active front-end for continuous test bench operation. This concept introduces a lot of harmonics into the 3-phase grid and the full load power must be transferred through the grid. Furthermore converters with an active front-end are much more expensive and the complete test-bench is quite inflexible.

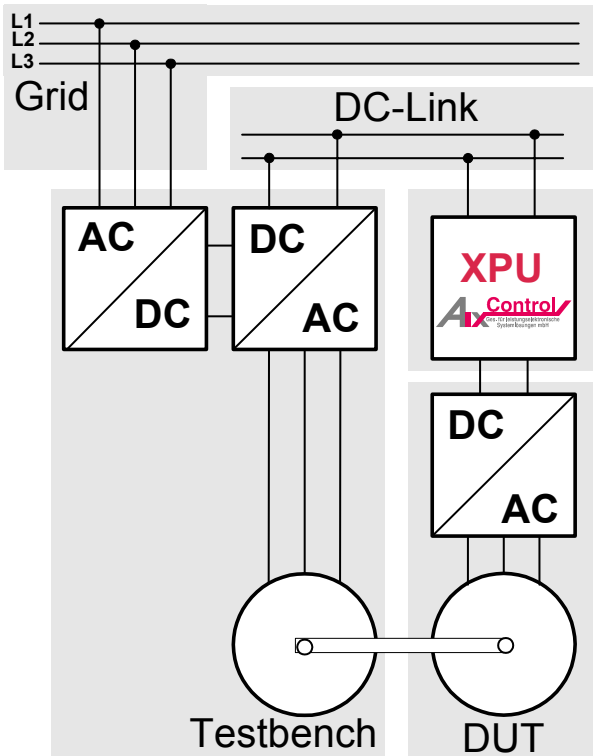

The new XPU 700 concept eliminates all these drawbacks. The basic idea is to connect the device under test (DUT) directly to the dc-link of the test bench via an isolated power converter. Thus the grid has to deliver power only to compensate the system losses and during periods of acceleration. The main energy flows through the dc-link only.

- ◆ A standard converter serves as power input from the grid.
- ◆ The XPU 700 connects the dc-link with the device under test (DUT).
- ◆ XPU 700 offers a galvanic isolation and a fully bi-directional output source.

The XPU 700 can emulate the behavior of a battery block by controlling the output voltage according to the output voltage and/or output amp-hours (state of charge controlling). These tests are inevitable for developing and testing drives that are especially aimed to the growing market of hybrid vehicles.

MODULAR TWO-STAGE CONCEPT

The XPU 700 consists of two power stages connected in series. With the first stage a galvanic isolation combined with a voltage adaptation is realized. The second stage works as a 2 quadrant chopper and is used to control the output voltage and currents of the system. Each stage is designed to work fully bi-directional for sinking and sourcing currents. A power scaling is achieved with a modular galvanic isolation. With highly integrated modules of 50 kW power rating the overall power rating of the XPU 700 can be scaled to the desired value.

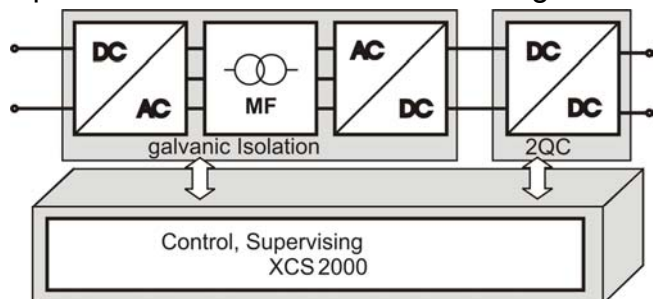

COMPREHENSIVE PROTECTION MECHANISMS

To fulfill the special requirements in testing environments the XPU 700 has been equipped with multiple protection mechanisms. E.g. it is protected against short circuits, high or negative voltages, over temperature and over currents. For more details please contact us.

Contact: Dr. Jochen von Bloh
 Address: AixControl GmbH
 Jaegerstraße 17/19
 52066 Aachen
 Germany

Phone: +49-241-80 969 64
 Fax: +49-241-80 922 03
 E-mail: info@aixcontrol.de
 Web: <http://www.AixControl.de/>